

20-030 and 20-035 Electromagnet

Instructions and Applications Written by Dr. P.G. Matlocks

Introduction:

This compact electromagnet is able to lift 100 times its weight - up to 200 pounds (20-030) or 500 pounds (20-035), with only one or two 1 1/2 volt D cell batteries as a power source! This is due to precision machining of the flat surfaces (core and yoke). Compare it to cranes that can lift derelict automobiles around a junk yard. These cranes use electromagnets similar in principle to this one, although with higher power requirements. This style of crane is practical since it can be switched on and off remotely and loaded and unloaded by one person.

Warranty and parts:

We replace all defective or missing parts free of charge. All products warranted to be free from defect for **90 days**. Does not apply to accident, misuse or normal wear and tear.

For best results:

- **Do not scratch mating surfaces.** Keep mating surfaces clean, smooth and undamaged. If surfaces do not mate properly, poles appear which reduce strength. Smear grease or oil between use or while storing. Remove before using.
- **Do not operate near a watch, color TV or other electrical appliance.**
- **Do not switch on current until surfaces are aligned** to prevent damage from sudden impact.
- To calculate the force required to remove the yoke, compare the energy contained in the magnetic field with separation of the yoke. It should agree with the 200 pounds found experimentally.

Operation Requires:

one or two D cell batteries

Activities

Demonstrate Holding Force

A quick way to demonstrate holding force is to connect batteries, place core and yoke together, and try to pull apart with your two hands. If your surfaces are flush and connections good, you will not be able to separate the parts. Now disconnect battery. Parts remove easily.

For a quantifiable demonstration, you will need:

- Weights
- Tray for holding weights
- Safety strap
- Connection to beam!

Hang magnet as shown in *Figure 1.2*.

Add known weights to tray until yoke falls off.

The safety strap will catch the yoke but not the tray, provided the tray was initially only a

few inches above the surface. If conditions are right, surfaces smooth, tray loaded and hanging correctly, you can carry over 200 pounds.

Reverse connections and confirm the same load can be carried.

Variations: Stand on a bathroom scale underneath the magnet and pull down on the yoke. (Take care the yoke does not hit your head. Avoid the in ropes!) The reading on scale will decrease by amount of the force between magnet and yoke. If you weigh 240 pounds and the yoke separates at a reading of 40 pounds, the maximum holding force is 200 pounds. If you weigh less than 200 pounds, this little magnet should be able to bear your full weight.

Dependence on Current

1. Attach as in first demonstration
2. Change the current as shown:

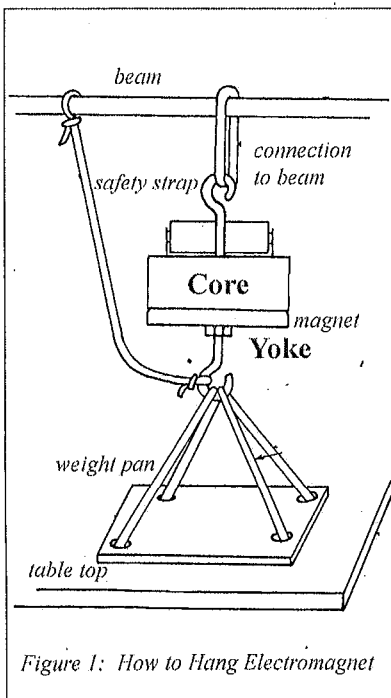

Figure 1: How to Hang Electromagnet

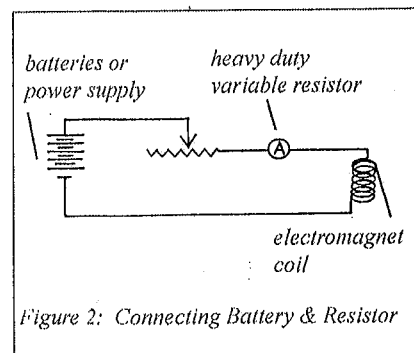

Figure 2: Connecting Battery & Resistor

3. Place known weight on tray and vary current until it falls.

Graph load against current and note that load does not increase linearly with current. This is because the iron is well magnetized and approaching saturation. (See **Theory** in following sections.)

Warning: The coil will overheat in a few minutes with currents of 2 or more amps.

Dependence on Gap

1. Repeat procedure above.
2. Place **one or more layers of aluminum foil** (about .005 inch, depending upon type of foil) between electromagnet and yoke.

Because aluminum is nonmagnetic and no free poles appear at iron surface, the effect of coil current on iron is reduced. Even one thousandth of an inch of foil will reduce the holding force to 100 lbs. This confirms the need for smooth surfaces in an electromagnet.

Replace iron yoke with other substances

1. In place of yoke try other materials - **copper, aluminum, brass** etc. Confirm that these materials are nonmagnetic.
2. Use core of magnet to **lift other iron objects in addition to yoke**. Use iron objects with flat surfaces free of rust and paint (i.e. base of iron cooking pot; base of carpenter's wood plane). Try to attain holding forces of 40 lbs.

Remanence

1. Put yoke in place and connect coil to cell for a few seconds so domains are aligned as before.
2. **Disconnect coil**. You will need to apply a few pounds of force to pull yoke off. Not all domain walls moved back when cell was disconnected. Due to the closed magnetic circuit, there are no free poles even in iron to drive domain walls back past the few pinning sites.
3. **Pull yoke off to break magnetic circuit**. Reapply yoke. You'll see that little force is required to pull it off again.

Demonstrate Induction

The remanence noted above may be used to demonstrate induction.

1. When disconnecting coil from cell, **connect coil to DC voltmeter**.
2. **Pull off yoke**. Voltmeter will briefly register an **induced voltage**.

This is because magnetism in the iron is collapsing as domain walls are driven back by free poles. This, according to Lenz's Law, induces a voltage in the coil in order to sustain the magnetism. It tries to replace current that magnetized the iron in the first place. The clip connected to positive cell

terminal will therefore be negative during induction and vice versa.

Because the induction is brief, the value obtained cannot be predicted because it is too dependent on voltmeter response-time. An **ammeter** can also be used to detect the brief flow of current of a few milliamperes that results.

Force on the Coil1. Remove spring clip that holds coil in place.

1. Use special pliers or loop wires through holes and pull carefully.
2. Replace and reconnect coil.

Note that coil moves freely. There seems to be little force between coil and iron. But a force must exist. Electrons moving in wire must interact with spinning electrons in iron. It is a weak magnetic force but weak because coil is small. *(The 200-pound force came from much larger spinning current in the iron on both sides of the mating surfaces.)*

3. To confirm the existence of the small force, hold magnet on its side with coil balanced in opening, as shown.

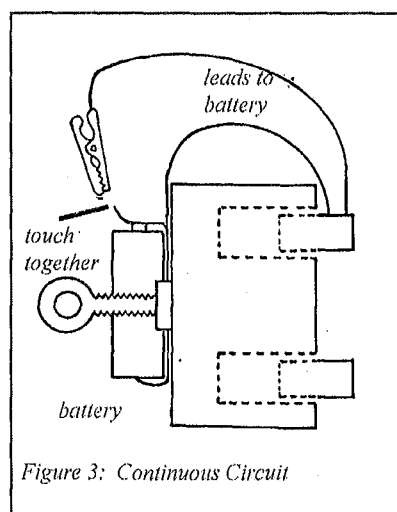

Figure 3: Continuous Circuit

4. Switch on battery. Watch coil jerk slightly inwards. (Direction is always inward regardless of polarity.)

Dependence on Temperature (Curie Temperature)

1. Hold steel wire coat hanger close to electromagnet. Observe attraction.
 2. Heat same short section of wire with propane torch.
- Warning: Do not heat electromagnet!

Observe that red-hot steel is no longer attracted but that on cooling magnetism is restored. At high temperatures, thermal agitation destroys alignment within each domain.

When a few spins are shaken out of alignment, their influence is lost over neighboring spins which in turn are more easily shaken. The magnetic character does not trail off over an ill-defined temperature range but drops at an increasing rate until it vanishes at a particular material-dependent temperature (the **Curie Temperature**, or T_c .) For iron, T_c is 770°C ; in contrast, red heat becomes just barely visible in a dark room at about 700°C . There is no connection between these two effects but red heat does make a useful thermometer.

There are two other common magnetic materials. The **flint** found in cigarette lighters, an alloy of iron and curium, is magnetic with T_c of about 100°C . Suspend a cigarette lighter on cotton thread and observe as it pulls to the electromagnet. Dip in boiling water; the attraction disappears until the flint cools.

Some **brass screws** are **nickel-plated**. The nickel is ferromagnetic with T_c of 360°C . Despite thin plating, if you suspend the screw by a brass wire, you'll see attraction to the electromagnet. Gentle heating - *take care not to melt wire!* - will cause the nickel to become nonmagnetic *below* red heat but *above* boiling water temperature. Canada uses enough nickel in their "silver" coins to cause them to be magnetic.

These thermal properties are employed in magnetic heat engines.

Exploring magnetic field around electromagnet

1. Place sheet of cardboard (or other nonmagnetic material) over upturned face of magnet.
2. Sprinkle iron filings over the magnet face.

Use a small hand-held compass to identify poles. The North pole of the compass (that which **seeks** the Earth's North Pole) will point to the South pole of the magnet (which **seeks** the South pole of the Earth).

Theory

Part One: Background

Sailors have known of naturally occurring permanent magnets for thousands of years. In the 1800's, connections between magnetism and electricity were studied by Ampere, Maxwell, Biot-Savart, Curie etc. Together their equations "solve" (accurately predict outcome of) given physical situations. But these were of a phenomenological nature. While equations quantified the observed mathematical relationships between electricity and magnetism in the form of "laws", they did not give insight into why there should be two seemingly different but related effects as **magnetism** and **electricity**. Both were seen to depend upon electric charge.

Most people believed these intertwined but apparently different effects had common explanations. Einstein's Theory of Relativity (1905) provided the missing connection. It stated that length, time and mass transform according to the relative velocity between observer and observed. Even though a stationary electric charge produces certain effects on its surroundings (described as an **electric field**) the electric charge, when moving, produces a different effect due to those transformations. This effect is what is described as the original electric field due to static charge, plus a magnetic field caused by the movement of the charge. In this case, the magnetic field is a relativistic correction to the electric field.

In other situations you can regard the electric as a relativistic correction to the magnetic field. Generally, neither electric nor magnetic fields are special. Tensor equations in Einstein's Theory relativistically transform electric and magnetic fields into each other according to velocity. You can regard them as different manifestations of the same thing connected by relativity. In a sense this is the same as the phenomenological laws. Relativity was postulated because the velocity of light was the same for all observers. But relativity is also connected to and between electricity and magnetism. Einstein's aim was to connect as many observations with as small a set of postulates as possible. Further theories link electromagnetism to nuclear and gravity.

A further advance in the study of magnetism unfolded during the early twentieth century. Quantum Mechanics (QM) "explains" the different types of magnetism found in elements and compounds and the fact that other materials were essentially nonmagnetic. "Explain" in this sense means to provide the connections with other known phenomena such as periodicity of the elements, atomic spectra, electrical conductivity, and, later superconductivity and semiconductivity.

Part Two: Magnetic Materials

Moving electric charge produces magnetic effects. Atoms of all elements each have at least one electron which spins on its own axis and orbits the nucleus. Why, then, is magnetism limited in the real world? In most materials, one or more of the possible levels cancel each other out. Cancellation at all levels is avoided in only a few materials.

The lowest level of cancellation occurs in the inner orbitals of atoms. These orbitals, when full, have even numbers of electrons with equal numbers spinning in opposite directions. The magnetic effects of counter-movements cancel. (When orbitals which are not full become full, atoms combine to form solids. Cancellation results.)

The only atoms that survive this level of cancellation are the transition and actinide metal atoms. Here the **d** and **f** orbitals are not fully involved in the formation of solids. When the d and f orbitals are not filled, cancellation is not inevitable, and each atom, even in a solid, may have the properties of a tiny-bar magnet. At this level thermal agitation causes the tiny magnets to point in different directions with an overall cancelling effect. The only survivors are those tiny magnets which have the right crystal structure and separation between atoms. In such cases the Quantum Mechanical Effect (**exchange interaction**) is strong enough to overcome the thermal agitation. QM asserts that there can be no chance of finding 2 electrons spinning in the same direction at the same position.

All electrons have a negative charge which causes mutual repulsion. Antiparallel electrons that QM allows to come close together have a higher energy than the parallel ones that QM has kept apart. The parallel spin arrangement favors lower energy. The strength of this effect depends on the energy difference which in turn depends on how electrons move around atomic nuclei and crystals.

In pure Fe, Co, Ni and Gd, and in compounds containing one or more of these, the effect can be strong, leading to parallel alignment of spins and orbital motion. These are known as **ferromagnets**. Pd and Pt are almost ferromagnet. Other effects come into play in Cr, Mn and the rare earths (other than Gd), La through Lu, giving rise to complex and beautiful spiral or alternating alignment of spins. In all cases, at elevated temperatures, thermal agitation will eventually destroy the alignment and cause cancellation.

By the 1980's the vast majority of low temperature aligned configurations were understood and predicted (retroactively) from the starting point of knowing how many electrons were on each atom.

(Note that the very first level of cancellation - that of full orbitals with equal numbers of opposite spins - was really an example of the antiparallel pairs of spins having the lowest energy as a consequence of electron motion around the nucleus, the division into orbitals and the structure of the Periodic Table itself.)

One more level of cancellation exists. A piece of Fe, Co, Ni or Gd may not necessarily be a magnet, even though the spins of millions of its atoms are aligned in parallel fashion. The piece of Fe, for instance, even though one continuous solid, contains subdivisions called **domains**. Within one domain, all spins which are essentially parallel differ from neighboring domains which may point in different directions, as shown.

Figure 4 is greatly simplified by enlarging domains and reducing their number. Actually domains are a fraction of a millimeter in size with many thousands represented.

The situation can be compared to throwing many magnets (corresponding to domains) into a box (corresponding to the solid piece). They clump together trying to stay opposite each other, thus cancelling each other out.

To overcome cancellation, take a short piece of wire (ex. copper) carrying an electric current **i**. The current is a flow of electrons along the wire. The direction of current is, by convention, that of positive charges opposite to the electron flow. The current produces a magnetic effect shown by imagining lines (**magnetic field**) as in Figure 5, below.

The line in Figure 5 represents the path the North pole of a magnet follows if allowed to move slowly. (If allowed to move freely, it would move too quickly and overshoot.)

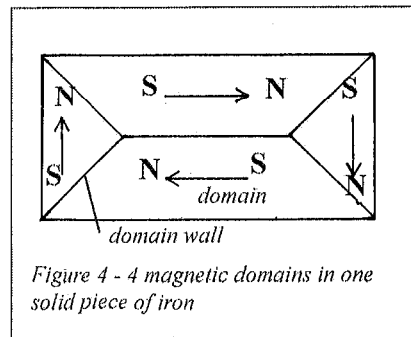

Figure 4 - 4 magnetic domains in one solid piece of iron

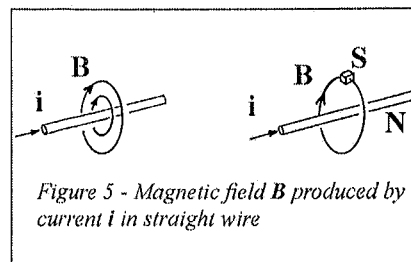

Figure 5 - Magnetic field **B** produced by current **i** in straight wire

The lines are clockwise diodes centered on the wire. Those lines close together near the wire indicate a strong force; those far apart, a weak force. The South pole of a magnet would move the opposite way with the same force. However, North and South poles cannot be isolated. Put a small magnet as shown in **Figure 5**; it will line up but not move. The effect of a current carrying coil of wire (an **electromagnet**) can move. The electromagnet is therefore the sum of all contributions from all little pieces of wire.

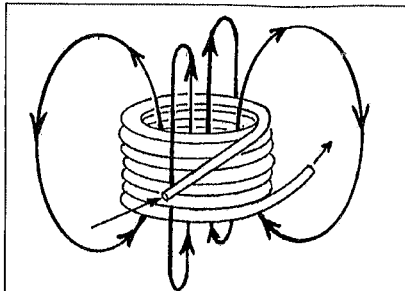

Figure 6 - Magnetic Field produced by Solenoid

Put a piece of non-magnetic material, such as copper, inside the coil depicted in **Figure 6**, above. Little will happen because the field is too weak compared with thermal agitation to change the spin orientations. Add iron, on the other hand, and you benefit from the alignment that has already taken place. The field from the coil reorients the already aligned spins. When the spins in the domain walls rotate towards the field, the domain walls move through the iron piece. Some domains grow while others shrink - as in **Figure 7**.

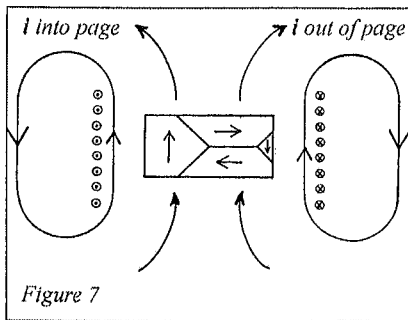

Figure 7

The last level of cancellation is incomplete. The iron has thereby become a **magnet**. The effect is temporary; switch off the current and domain walls move back. The magnetism is lost. The iron in a magnet of this type is a **soft ferromagnet**.

With appropriate impurities (C or Cr in steels) or with appropriate texturing of materials into powder (as in ceramics or samarium cobalt) the domain wall can be pinned so that it does not move back past the impurities. Un-

der these conditions, switching off the current still leaves a bulk magnet. These, called **hard ferromagnets**, are the materials used to make **permanent magnets**. Of course, the pinning of the domain walls make it correspondingly difficult to magnetize in the first place. Very high currents are used in short pulses to prevent overheating.

Part Three: Magnetic Circuits and the Electromagnet

The domain wall movement shown in **Figure 7** will not progress very far. As the preferred domains grow, they build up North and South poles at the ends of the iron. Although that appears desirable, it impedes the magnet's strength. Those "free" poles produce their own magnetic field through the iron in the opposite direction. The coils' effectiveness is therefore impaired. The field is not strong enough to completely magnetize the iron. To combat this **negative feedback**, the 20-030 & 20-035 electromagnet is designed with a continuous circuit of iron. Ideally there are no ends or free poles, as in **Figure 8** below.

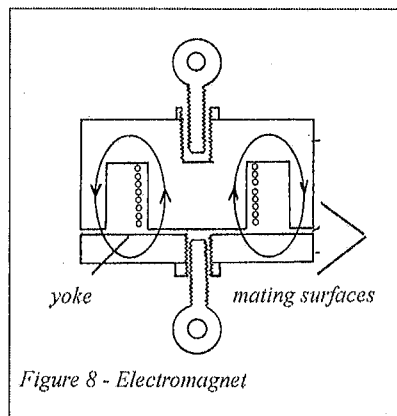

Figure 8 - Electromagnet

Figure 8 represents the case in which the iron is almost completely magnetized but with no poles. The spinning electrons, and not the poles, after all, do the attracting. Since each side of the mating surface has the same orientation, these electrons attract. If you increase the coil current you accomplish little because the iron is already almost fully aligned (or **saturated**). Examples of complete magnetic circuits may be found in transformers and in the inductive pickup devices that automobile mechanics clip around sparkplug leads to trigger stroboscopic lights.

Energy Considerations

It is a common misconception that magnets provide power at no expense.

According to Quantum Mechanics, the electrons prefer to be aligned within a domain. A domain is a lower energy state. For example, if you heat iron to bright red, you can measure the extra energy needed to destroy this magnetic state. Conversely, energy is given off on cooling.

Aligning all domains in the iron core of the 20-030 and 20-035 **Electromagnet** requires energy. Such energy is supplied by the battery. Once aligned, no further power is required: a superconducting coil could carry the same current to keep the domains aligned at no energy cost. With the copper coil, however, its finite resistance requires the power of the battery to sustain the current. The electrons in the iron spin forever. They cannot stop and so require no more energy.

You must therefore supply a significant amount of work to pull the yoke from the magnet. You get most of it back again when the yoke is placed back on the electromagnet. All energy can be accounted for in every conceivable situation.

The electromagnet is therefore a practical demonstration and use of the magnetic forces that have been described theoretically.

How to Teach with Electromagnet

Concepts: Electromagnet; solenoid; electromagnetic attraction and repulsion; magnetic and nonmagnetic material; magnetic domain & energy level; magnetic circuits.

Curriculum Fit: PS/ Electricity & Magnetism. *Unit: Moving Charge & Magnets, Grades 9-10.*

Specifications:

Coil has 175 turns of 4 parallel strands #28 wire 24 meters long and is 71 grams.
 1.389 meters/gram 4.70 meters/ohm
 1.75" diameter 14 cm per 4 m.
 Resistance each strand: 6 ohms
 Combined resistance: 1.50 ohms
 Average turn diameter: 14 cm.

P/N 24-20030

©Science First/Morris & Lee All Rights Reserved. Science First© is a registered trademark of Morris & Lee. Revised 05-08